



DAISY CHAIN STRIPPY QUILT

free pattern



DAISY CHAIN STRIPPY QUILT

Fabric designed by Amy Butler for Rowan
All prints are from Amy's Daisy Chain Collection
The solids are from Amy's Solid's Collection

Quilt design by Amy Butler
Quilt construction and instructions by Beth Hall
Machine quilting by Cheryl Lorence

Finished Size: 60 1/2" wide x 76 1/2" long

Amy Butler fabrics used in the Strippy Quilt on the front cover and also shown to the right

Fabrics used for the Quilt Blocks

ab-40
sweet jasmine

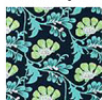

navy

ab-39
pressed flowers

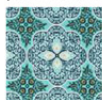

turquoise

ab-42
dandelion field

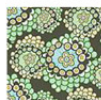

forest

ab-41
clematis



green

ab-35
mosaic



green

ab-38
daisy bouquet



turquoise

ab-42
dandelion field

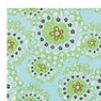

mist

ab-41
clematis



natural

Sparkle fabrics

ab-38
daisy bouquet



natural

ab-37
kaleidoscope



leaf

ab-45
quilting solids



green

ab-45
quilting solids



mist

Fabric used for Border

ab-37
kaleidoscope



natural

Fabric used for Binding

ab-36
happy stripe

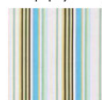

river

Fabrics used for the Quilt Back

ab-40
sweet jasmine



navy

ab-35
mosaic



river

NOTES: All seam allowances are 1/4" unless otherwise stated.

Before you get started, please read through all of the instructions. Then preshrink your fabric by washing, drying and ironing it.

TIP: Making a small diagonal clip in the corner of each of the fabrics before washing will prevent fraying and tangling.



Daisy Chain Strippy Quilt Front (Color Story #1)

Materials List

- 8 (3/4 yard) assorted prints for the Strips for the Quilt Blocks

For Color Story #1:

- 4 (3/4 yard) "sparkle" fabrics (we use some solids and some stand out fabrics to make the quilt "sparkle")

For Color Story #2 (shown on the back cover):

- 3 (1 yard) "sparkle" fabrics

PLUS for either Color Story #1 or #2:

- 2 yards of a coordinating fabric for the Borders
- 2 1/3 yards of 2 coordinating prints for the Backing
- 3/4 yard of a third coordinating fabric for the Binding
- 3 1/8 yards of 44" wide lightweight muslin for the block foundation
- 1 queen size batting (we use bamboo batting from Fairfield)
- 1 large spool of coordinating all-purpose thread (we use Coats Dual Duty XP®)

Tools Needed

- Ruler/rotary ruler
- Rotary cutter and mat
- Scissors
- Straight pins
- 8 1/2" x 8 1/2" square quilting ruler
- Safety pins (Large size)
- Pencil or fabric marker
- Hand sewing needle
- Iron and ironing board

Step 1.

CUT OUT THE FABRIC PIECES

A. Cut the Strips below along the crosswise grain the total width of your fabric.

For Color Story #1:

From each of the 12 (3/4 yard) total cuts of fabric:

- Cut 2 5" Strips
- Cut 2 3" Strips
- Cut 2 2 1/2" Strips
- Cut 2 2" Strips
- Cut 1 1 1/2" Strip

For Color Story #2 (shown on the back cover):

From each of the 8 (3/4 yard) cuts of fabric:

- Cut 2 5" Strips
- Cut 2 3" Strips
- Cut 2 2 1/2" Strips
- Cut 2 2" Strips
- Cut 1 1 1/2" Strip

From each of the 3 (1 yard) cuts of "sparkle" fabric:

- Cut 3 5" Strips
- Cut 3 3" Strips
- Cut 2 2 1/2" Strips
- Cut 3 2" Strips
- Cut 1 1 1/2" Strip

For Color Story #1 and #2:

From each of the 3" and 2" Strips:

- Cut 4 to 5 13" Strips from each fabric

B. You will need a total of 96 (13") Strips. You will use 2 of these Strips to start the piecing on each Block.

From the 1st Backing fabric:

- Cut 3 strips 12 1/2" wide x 84" long

From the 2nd Backing fabric:

- Cut 3 strips 12 1/2" wide x 84" long

From the Border fabric:

- Cut 4 strips 6 1/2" wide x 72" long

From the Binding fabric:

- Cut 8 - 2 1/2" wide strips, enough to make 280" of binding

From the muslin:

- Cut 48 - 9" squares

Step 2.

PIECE YOUR QUILT BLOCKS

NOTE: Randomly pick Strips varying in width and color to give a scrappy look.

A. On the first muslin square, using your ruler and pencil, draw a line 1/4" to the left of 2 opposite corners on the square.

B. Place two 13" Strips **RIGHT** sides together matching one long raw edge. Then place these matched edges along the marked line on the muslin square. Pin them in place. Stitch a 1/4" from the matched edges.

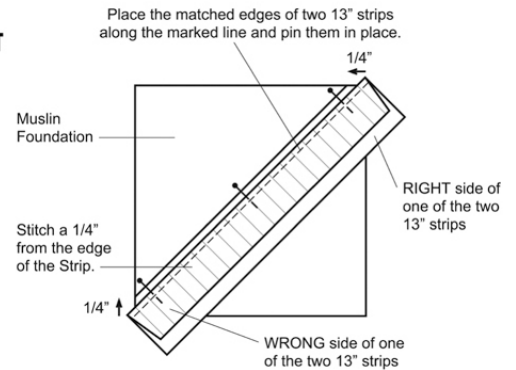

C. Then open the Strips so the **RIGHT** sides are facing up and press them away from the seam. Pin them in place.

D. Next, place one long edge of a third Strip even with the other long edge of the right center Strip. Pin in place. Cut off the remaining part of the Strip, leaving 1/2" past the foundation block. Stitch a 1/4" from the matched edges.

E. Turn the Strip **RIGHT** side up and press it away from the seam.

F. Repeat Step 2D and 2E to attach more Strips until the right side of the quilt square is covered.

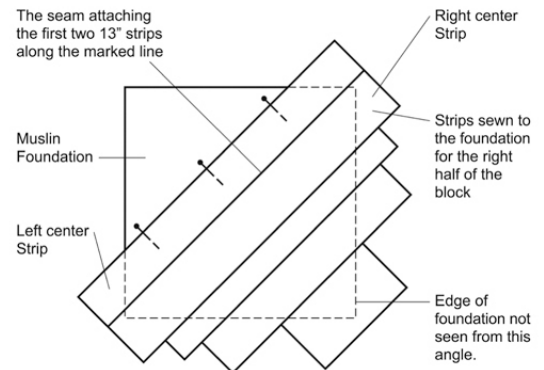

G. Starting back at the left center Strip. Match the long edge of the next Strip with the other raw edge of the left center Strip. Pin in place. Cut off the Strip 1/2" past the foundation block. Stitch a 1/4" from the matched edges. Turn the Strip over and press it away from the seam.

H. Repeat Steps 2D and 2E to attach more Strips until the left side of the first square is covered.

I. Repeat Steps 2A through 2H to attach Strips to the remaining squares.

Step 3. **SQUARE UP EACH QUILT BLOCK**

A. Using a small rotary mat and cutter, center the 8 1/2" x 8 1/2" quilter's ruler in the middle of the first block. Cut along one side, turn the mat and cut the next edge until all 4 edges have been cut making a true 8 1/2" x 8 1/2" square.

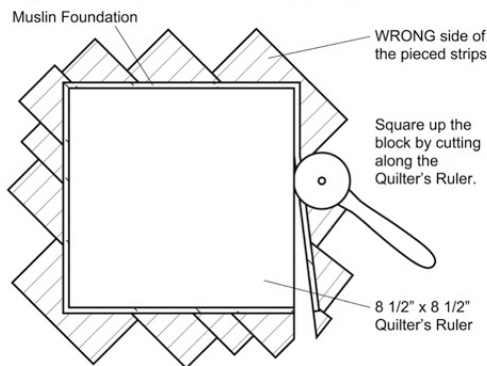

B. Repeat Step 3A to square up the remaining blocks.

Step 4. **ASSEMBLE THE QUILT BLOCKS**

NOTE: All seam allowances should be pressed open to help relieve some of the bulk in the seams.

A. Use the diagram for the Strippy Quilt in Step 5. Lay the blocks in the pattern shown. Each Block is laid with the diagonal Strips facing the opposite direction from the previous one.

B. Then place the first two 8 1/2" blocks from the 1st row **RIGHT** sides together (the design on the squares will lay opposite each other). Pin them in place. Stitch a 1/4" seam down one side edge and backstitch at each end. Press the seam allowances open. Lay the attached blocks back in place.

C. Then place the first 2 blocks from the second row **RIGHT** sides together and pin them in place. Stitch a 1/4" seam down one side edge and backstitch at each end. Press the seam allowance open. Lay these blocks back in place.

D. Next place the first 2 sets of attached blocks **RIGHT** sides together matching the center seams and pin them in place. Stitch a 1/4" seam across one long edge to make a larger 16 1/2" square Block and backstitch at each end. Press the seam allowance open.

E. Continue this process to make 12 -16 1/2" blocks, 3 across each row and make 4 rows.

F. Then place the first two 16 1/2" blocks **RIGHT** sides together matching the center seams and pin them in place. Stitch a 1/4" seam across one long edge and backstitch at each end. Press the seam allowance open.

G. Repeat Step 4F to attach three 16 1/2" blocks across for the top row and three 16 1/2" blocks together for each of the other 3 rows.

H. Then place the first 2 rows together matching all the seams and pin it in place. Stitch a 1/4" seam across the two rows and backstitch at each end. Press the seam allowance open. Match the top edge of the 3rd row of blocks with the bottom edge of the second row of blocks, repeating this process. Then attach the 4th row to the bottom of the 3rd row in the same way.

Step 5. **ATTACH THE BORDERS TO THE QUILT CENTER**

A. Place one long edge of the first Border **RIGHT** sides together matching the left of the attached Quilt Center. Pin it in place. Stitch a 1/4" seam down the matched edges and backstitch at each end.

B. Open the Border and on the **WRONG** side press the seam allowance toward the Quilt Center.

C. Repeat Step 5A and 5B to attach the second Border to the right of the Quilt Center.

D. Use your rotary ruler, cutter and mat, and trim both of the Side Borders even with the top and bottom edge of the Quilt Center.

E. Place the next Border **RIGHT** sides together with the top edges of the Side Borders and of the Quilt Center. Pin it in place. Stitch a 1/4" seam across the matched edges and backstitch at each end. Repeat to attach the bottom Border.

Now your Quilt top is complete. Press it flat.

Step 6. **MAKE THE QUILT BACK**

A. Lay out the fabric for the back of the quilt by alternating the Strips.

B. Place the first 2 strips **RIGHT** sides together matching one long edge and pin it in place. Stitch a 1/4" seam down the pinned edge and backstitch at each end. Press the seam allowance open.

C. Open the first 2 attached Strips. Place the third Strip **RIGHT** sides together on the other long edge of the second Strip. Pin it in place. Stitch a 1/4" seam down the pinned edge and backstitch at each end. Press the seam allowance open. Repeat this process to attach all the Backing Strips.

Step 7. **ASSEMBLE THE QUILT**

A. Place the Backing on a large flat surface with the **WRONG** side up. Smooth out any wrinkles.

B. Place the batting on the **WRONG** side of the Backing. Smooth out any wrinkles.

Daisy Chain Strippy Quilt Diagram

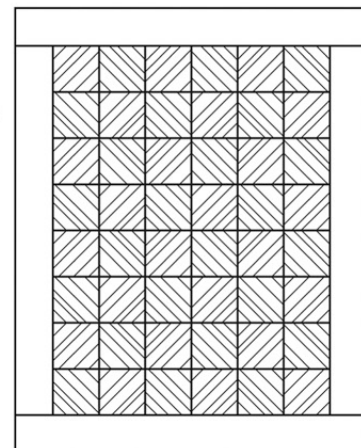

C. Center the completed Quilt Top on top of the Batting with the **RIGHT** side facing up creating a sandwich of the Backing, batting and Quilt Top and smoothing out any wrinkles.

D. Use safety pins and pin the layers together or hand baste the layers together using long basting stitches.
To hand baste, make a series of long, running stitches through all of the pinned layers.

E. Machine or hand quilt as desired beginning at the center of the Quilt and working your way to the outside edges. When the quilting is complete, trim the Backing, batting and Quilt Top evenly using a ruler, fabric marker and scissors, or a rotary ruler, mat and cutter.

F. Hand or machine baste very close to the raw edges to secure the 3 layers together before adding your binding.
To machine baste, use the longest stitch on your machine, so you can easily remove the basting stitches later. Do not backstitch at the end of your stitching.

Step 8. **MAKE AND ATTACH THE BINDING**

A. Join the binding strips into one continuous piece by placing the ends of the strips perpendicular to each other with the **RIGHT** sides together. Stitch diagonally across the matched edges, backstitching at each end, and trim the seam allowance to 1/4". Press the seam allowance open and trim any "tails" of fabric along the edges of the seam. Continue to join strips until you have a piece measuring 280" long.

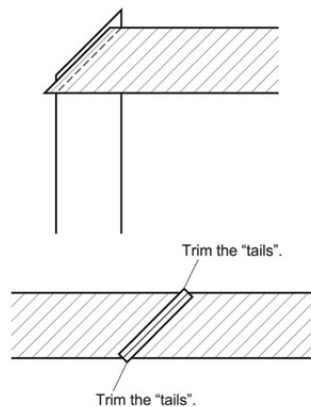

B. Fold the strip in half lengthwise with the **WRONG** sides together. Press a crease along the fold.

C. With the **RIGHT** side of the Quilt Top facing up and beginning in the center of one side edge, align the raw edges of the Binding with the raw edge of the Quilt leaving 5" unattached. Pin in place. Stitch the Binding using a 1/4" seam. Stop 1/4" from the first corner and backstitch. Clip the thread and remove the Quilt from the sewing machine.

D. To form a neat mitered corner, fold the Binding strip away from the Quilt at a 45° angle, and then fold it back onto itself, even with the next raw edge of the Quilt. Pin in place. There will be a folded edge of Binding even with the first edge of the Quilt.

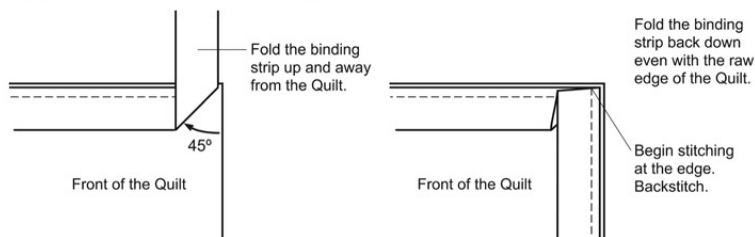

E. Begin stitching again at the upper edge of the Quilt, backstitching as you begin. Continue to pin and sew to 1/4" from the next corner, backstitch and repeat the mitering process.

F. Continue to attach the Binding and miter all four corners. Stop stitching 10" from where you first began. Backstitch at the end.

G. Cut the Binding so it overlaps its beginning edge by 6". Open the unattached beginning end of the Binding and cut it at a 45° angle. Fold under 1/2" toward the **WRONG** side. Press and refold.

H. Insert the end of the Binding within the folded beginning edge. Adjust so that they lay flat within each other, tucked inside the fold. Pin and stitch the Binding in place.

I. Turn the Quilt over so the Backing is facing up and flip the binding over the edge from the front to the back. Line up the folded edge of the Binding so it just covers the stitching line that attached it to the front. Adjust the mitered corners and pin them in place.

J. Hand stitch the Binding in place or machine stitch close to the folded edge of the Binding.









Your Quilt is complete!!

Be sure to add a fabric label to the Quilt back, hand stitching it in place to document your name, address, date and any information you may want to include (perhaps a dedication or a name for the Quilt). Future generations will thank you for this.



Amy Butler fabrics used in the Strippy Quilt shown to the right

Fabrics used for the Quilt Blocks

- | | | | |
|--|---|---|---|
| ab-41
clematis

turquoise | ab-40
sweet jasmine

mist | ab-37
kaleidoscope

olive | ab-38
daisy bouquet

mist |
| ab-41
clematis

grey | ab-40
sweet jasmine

grey | ab-42
dandelion field

grey | ab-38
daisy bouquet

forest |

Sparkle fabrics

- | | | |
|---|--|--|
| ab-41
clematis

forest | ab-45
quilting solids

slate | ab-45
quilting solids

ivory |
|---|--|--|

Fabric used for Border

- ab-45
quilting solids

ivory

Fabric used for Binding

- ab-36
happy stripe

grey

Fabrics used for the Quilt Back

- | | |
|---|--|
| ab-41
clematis

grey | ab-36
happy stripe

grey |
|---|--|



All designs © 2008 Amy Butler
Art of the Midwest, LLC

WESTMINSTER
FIBERS

3430 Toringdon Way, Ste 301
Charlotte, NC 28277
Phone: 866-907-3305
Fax: 864-877-3269

Email: fabrics@westminsterfibers.com
Website: www.westminsterfibers.com



If you enjoyed this quilt pattern, please be sure to check out my other free quilt patterns like "Amy's Mid Mod Quilt".

amybutlerdesign.com



Daisy Chain Strippy Quilt Front (Color Story #2)

