

FREE PATTERN DOWNLOAD

THE HOURGLASS PILLOW

(2 SIZES)

INSTRUCTIONS AND MEASUREMENTS

Hourglass Pillow (2 sizes)

The 1/2" seam allowance is included in all cutting measurements. Use the instructions below for making both size Pillows.

MATERIALS LIST FOR THE HOURGLASS PILLOW

NOTE: Please allow additional yardage for a one-way design or directional print fabric

For a 16" x 16" pillow

-5/8 yard of 44" wide mid- to heavyweight cotton print for one Hourglass shape and the back of the Pillow (Fabric-A)

-5/8 yard of 44" wide mid- to heavyweight coordinating cotton print for the second Hourglass shape (Fabric-B)

-2 - 1 1/2" buttons to cover for the center of the Pillow (They usually come 2 in a kit)

-1 - 16" square Pillow Form (we used Fairfield's "Soft Touch™" form)

-1 spool of coordinating thread

-Carpet or upholstery thread

OR to make your own Pillow Form, you will need:

-5/8 yard of 44" wide cotton muslin

-2 - 8 oz. bags of polyester fiberfill (we used Fairfield's "Soft Touch Poly-fill Supreme™")

For a 28" x 28" pillow

-1 3/4 yards of 44" wide mid- to heavyweight cotton print for one Hourglass shape and the back of the Pillow (Fabric-A)

-1 yd. of 44" wide mid- to heavyweight coordinating cotton print for the second Hourglass shape (Fabric-B)

-2 - 2 1/2" buttons to cover for the center of the Pillow (They usually come 1 in a kit)

-1 - 28" square Pillow Form (we used Fairfield's "Soft Touch™" form)

-Carpet or upholstery thread

-1 spool of coordinating thread

OR to make your own Pillow Form, you will need:

-1 yard of 90" wide cotton muslin

-4 - 8 oz. bags of polyester fiberfill (we used Fairfield's "Soft Touch Poly-fill Supreme™")

TOOLS NEEDED

- | | |
|--|---------------------|
| -Pen or pencil | -Scissors |
| -Straight pins | -Iron |
| -Yardstick | -Hand sewing needle |
| -Turning tool | -Seam Ripper |
| -Masking tape | |
| -Carpet or upholstery thread | |
| -3" doll makers needle or another long hand-sewing needle | |
| -Fabric marker or chalk pencil | |
| -Freezer paper or other large paper for making a pattern piece | |

FINISHED SIZE:

- Small Hourglass Pillow - 16" square
Large Hourglass Pillow - 28" square

IMPORTANT: Press your seams as you go so your Pillow will have a nice finished look.

Step 1. MAKE A PATTERN PIECE FOR THE HOURGLASS PILLOW

A. First, tape two pieces of freezer paper together to make a piece of paper large enough to make a pattern piece. Using your yardstick and a pencil, measure and mark on the large piece of freezer paper, the following measurements according to the size pillow you are making:

For the 16" x 16" pillow - Measure and mark a 19 1/4" square

For the 28" x 28" pillow - Measure and mark a 31 1/4" square

Then, with your scissors, cut the square out of the freezer paper.

B. Next, place your yardstick diagonally across the square, matching up the opposite corners and draw a line connecting the corners. Repeat this step to draw a line connecting the opposite corners. Then, cut along the diagonal lines you just drew for your pattern pieces. **NOTE: This will make four equal triangles, but you will only need one for a pattern piece. Keep the other three in case you cut or tear the first pattern piece.**

19 1/4" or 31 1/4" square

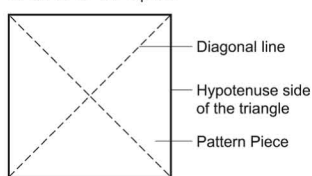

Step 2. CUT ALL OF THE PARTS OUT OF YOUR FABRICS

For the first Exterior Printed Fabric (Fabric A)

-Cut 2 Panels (Triangles) - Use the pattern piece you made in Step 1B for the size Pillow you are making. Place the hypotenuse of the triangle onto the lengthwise grain of your fabric and pin it in place. **NOTE: The hypotenuse is the longest edge of the triangle. Placing it on the lengthwise grain assures that the Pillow will not stretch out of shape.**

Mark these dimensions directly onto the **WRONG** side of your fabric by using your yardstick and pencil.

For the 16" x 16" Pillow - Cut 1 Back Panel - 17" square x 17" long

For the 28" x 28" Pillow - Cut 1 Back Panel - 29" wide x 29" long

For the second coordinating Printed Fabric (Fabric B)

-Cut 2 Panels (Triangles) - Use the pattern piece you made in Step 1B - Place the hypotenuse of the triangle onto the lengthwise grain of your fabric and pin it in place.

OPTION:

From the cotton muslin (For making your own Pillow Form)

For the 16" x 16" Pillow - Cut 2 Panels - 17" wide x 17" long

For the 28" x 28" Pillow - Cut 2 Panels - 29" wide x 29" long

Step 3. MAKE THE HOURGLASS FRONT OF THE PILLOW

A. Attach Hourglass Panels together - With the Triangles cut from Fabric-A and Fabric-B, place the first Triangle from Fabric-A, **RIGHT** sides together with the first Triangle from Fabric-B matching up the short, side raw edges of the triangles and pin them in place. Stitch a 1/2" seam across the matched raw edges, backstitching at each end. Press the seam allowance toward Triangle-A. Then, repeat this step attaching the other Triangle-B and A together. This will allow the Triangles to be opposite of each other once stitched together to form the Hourglass shape.

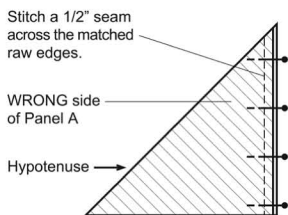

B. Attach Panels A/B and B/A together - With **RIGHT** sides together place Panel A/B onto B/A, butting up the seams, attaching the first and second sets of Triangles together and matching the long, side raw edges. Pin the matched raw edges in place. Attach by stitching a 1/2" seam across the matched raw edges, backstitching at each end. Press the seam allowance open.

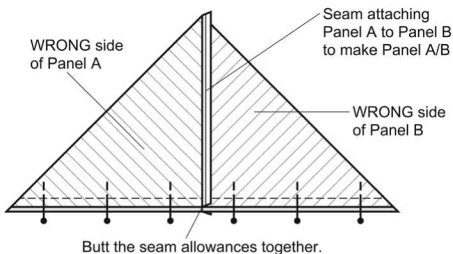

Stitch the larger triangles together with a 1/2" seam to form the Pillow Front.

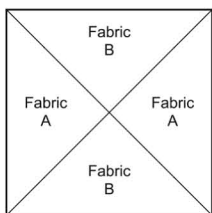

Step 4. MAKE THE EXTERIOR OF THE PILLOW

A. Find the center of the Back Panel for the placement of the Button - First, fold the Back Panel in half and gently press a crease along the fold. Then, fold the panel in half in the opposite direction and gently press a second crease. Open up the Back Panel. The point in the center of the panel where the two creases meet is the center of the Back Panel. Make a mark at the center point on the **RIGHT** side of the panel for placing your button in Step 6. Then, press the panel flat.

B. Cut two 4" squares out of the heavyweight sew-in interfacing and fold them in half twice, creating two 2" squares to be used as a stabilizer for attaching the buttons in the center of the Pillow. Place one of the stabilizer squares onto the **WRONG** side of each of the Pillow Covers at the center points and machine-baste them in place.

C. Place the **RIGHT** sides of the Front and Back Panels together, matching up the side raw edges and pin them in place. Attach by stitching a 1/2" seam around the matched raw edges, leaving a 14" opening (for the 16" pillow) OR a 26" opening (for the 28" pillow) centered on one side raw edge.

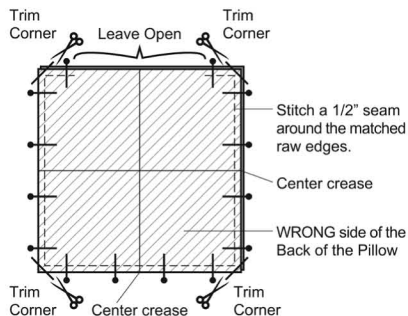

D. With your scissors, trim all four corners in the seam allowance, making sure not to clip your stitching.

E. Then, turn the Exterior Pillow Cover **RIGHT** side out, using a turning tool to push out the corners, and press it flat.

F. Insert the Pillow Form you purchased or make your own Pillow Form by following the instructions in Step 5, then continue to follow Step 4C.

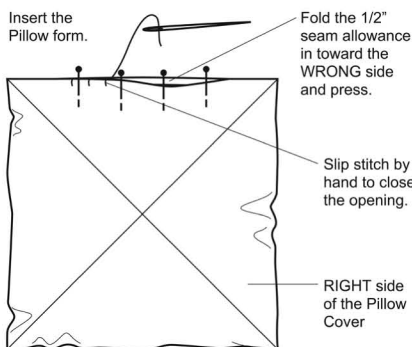

G. Now close the opening of the Exterior Pillow Cover by folding the 1/2" seam allowance in toward the **WRONG** side of the Exterior Pillow Panels on each side of the opening and press. Then, pin the opening closed. Slip stitch by hand to close the opening.

OPTION:

Step 5. MAKE A MUSLIN PILLOW FORM

A. First, take the two muslin Panels and place them **RIGHT** sides together, matching up the raw edges and pin them in place.

B. Attach by stitching a 1/2" seam around the panels, leaving an 8" opening, centered on one of the side raw edges, backstitching at each end.

C. With your scissors, trim all four corners in the seam allowance making sure not to clip your stitching.

D. Then, turn the pillow form **RIGHT** side out, using a turning tool to push out the corners, making them nice and square.

E. Fill the Pillow Form with the poly-fill to your desired firmness. Make sure to add the poly-fill to each of the corners.

F. Fold the 1/2" seam allowance in toward the **WRONG** side of the Pillow Form on each side of the opening and press. Pin the opening closed. Slip stitch by hand to close the opening and finish your Pillow Form.

G. Go back and follow Step 4G and insert your Pillow Form into the Exterior Pillow Cover. Then, close the opening on your Hourglass Pillow.

Step 6. MAKE AND ATTACH THE COVERED BUTTONS

A. First, follow the manufacturer's instruction to cover the two buttons with Fabric-A.

B. Using a doll maker's needle (or another long hand-sewing needle) and heavy thread, attach the ends of the thread to the loop on the back of the covered button by knotting it a couple of times in the same place.

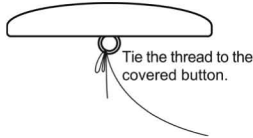

C. Push the needle down into the center on the front of the Pillow at the point where the triangles meet. Guide the needle through to the back of the pillow at the center mark you made in Step 4A, pulling the covered button onto the front of your Pillow. Then, take the needle and push it back up through the Pillow to the center on the front of the Pillow and pull the thread taut to indent the center of the pillow.

D. Knot the thread at the center of the front to hold the indented shape, but **DO NOT** cut the thread.

E. Next, push the needle back in through the center on the front of the Pillow and out at the center point on the Back Panel. Slide the second covered button onto the needle and again push it through the back of the pillow and out the center on the front, stitching through the loop on the button.

Continue this process a few times to secure the buttons in place on each side of the Pillow. Knot the thread a couple of times in the same place and then clip your thread to free your needle.

Side view of the Pillow showing how to attach the top covered button to the bottom covered button.

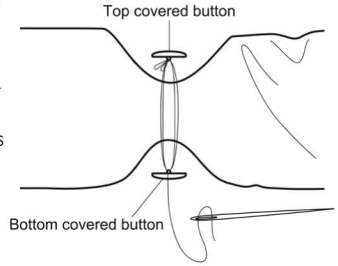

Your Hourglass Pillow is complete.

Glossary for the Hourglass Pillow

-Hypotenuse - The longest edge of a triangle.

-Interfacing - A stiffening fabric-like material used to give your project strength and durability. Interfacing also gives lighter weight fabrics stiffness and body.

-Machine-baste - A machine-baste stitch is used to hold sections of your project in place until you are ready to complete your final stitches. Use the longest stitch length on your machine. You do not have to backstitch at each end of your stitching.

-Slip stitch - You will need a long piece of thread and hand sewing needle. Thread your needle and knot the ends of your thread. Stitch back and forth between the opened seam, evenly spacing your stitching. Tie and knot off your stitching and cut the excess thread.

-Turning tool - A pointed tool that can be used to push the corners out on your project.
Example - A closed pair of scissors.

amybutlerdesign.com

All designs © 2006 Amy Butler - Art of the Midwest

PROJECT AND PATTERN ARE NOT TO BE REPRODUCED IN ANY FORM FOR RESALE. PATTERN INTENDED FOR FREE GIVE-AWAY OR TO BE INCLUDED IN KITS.

Your use of this pattern is conditioned upon your acceptance of the following terms. The written instructions, illustrations, photos, and patterns herein are intended for personal use only and are protected by copyright law. You are not buying the product or pattern design, but are only purchasing the license to use the pattern for personal use.

PROJECTS ARE NOT TO BE PRODUCED FOR COMMERCIAL SALE NOR ARE THEY TO BE SOLD TO ANY PERSON OR BUSINESS.

By using this pattern, you agree that the laws of the State of Ohio, without regard to the conflict of laws, will apply to all matters relating to use of this pattern. You also submit to the personal jurisdiction of Ohio and the venue of the state and federal Courts of Ohio.