



sweet greetings  
large & small portfolios

MIDWEST MODERN®  
SEWING PATTERNS



*Free  
Pattern!*



# Sweet Greetings Large & Small Portfolios

## SEWING PATTERN INCLUDES:

Instructions and measurements to create your own **SWEET GREETINGS LARGE & SMALL PORTFOLIOS**.

Designed to hold Amy's paper crafting projects inside. Perfect for organizing your cards, gift tags and other paper crafts.



Paper craft materials shown are from Amy's SOLA and BELLE collections from K&Company.

Pattern design and instructions by Nichole Redinger. Visit [www.nicholeredinger.wordpress.com](http://www.nicholeredinger.wordpress.com) to see more of Nichole's work.

**NOTE: All seams are 1/2" Unless otherwise stated (The 1/2" seam allowance is included in all the measurements)**

**Please read through all of the instructions before you get started on your project. Preshrink your fabric by washing, drying and ironing it before beginning.**

## Project One Large Portfolio

### Materials List:

- 5/8 yard of 44" wide lightweight cotton fabric (Fabric A)  
(We used Celery / Passion Vine hdabs4 and Olive / Wood Fern hdabs7 from Amy's NIGELLA fabric collection by Rowan)
- 3/8 yard of 44" wide lightweight cotton fabric to coordinate with the first fabric (Fabric B) (We used Moss / Wood Fern hdabs3 and Olive / Wood Fern hdabs7 from Amy's NIGELLA fabric collection by Rowan)
- 2 10" lengths of 1/2" wide ribbon (We used Amy's Sola Ribbon by K&Company - Product # 556607. You may also make fabric ties. Use the **OPTIONAL** Fabric Tie listed in Step 1.)
- 11" x 15" piece of 1/8" thick chipboard
- 5 Decorative Brads (We used Amy's Fabric Brads by K&Company - Product # 558366.)

### Tools Needed:

- AWL (Or the sharp point of a craft knife)
- Craft Knife
- Ruler
- Cutting Mat
- Turning Tool (Such as a closed pair of scissors)
- Scissors
- Pencil
- Sewing Needle
- Pins
- Sewing Machine

**Finished Size:** 7 1/2" x 11"

### Step 1.

#### CUT THE PIECES OUT OF YOUR FABRIC

- A. Cut out the pieces of fabric as follows:
- \*Outer Panels - 17" x 12" Rectangle - Cut 2 of Fabric A
  - \*Inner Panels - 8 1/2" x 12" Rectangle - Cut 2 of Fabric A
  - \*Cover Stripes - 2" x 12" Rectangle - Cut 2 of Fabric B
  - \*Pencil Pocket - 2" x 9" Rectangle - Cut 1 of Fabric B
  - \*Pockets - 6 1/2" x 5" Rectangle - Cut 8 of Fabric B
  - \*Pocket Appliqués - 2" x 4" Rectangle - Cut 2 of Fabric A
  - \***OPTIONAL** Fabric Tie - 2" x 11" Rectangle - Cut 2 of Fabric B

Layout for Fabric A

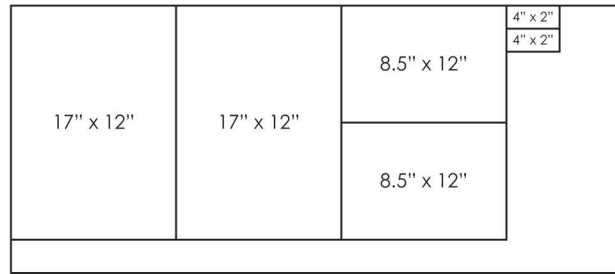

Layout for Fabric B

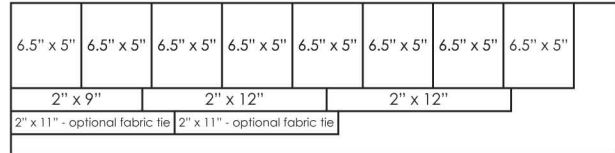

B. Cut out the Chipboard Stabilizers as listed below. Chipboard is slightly heavier than cardstock or regular cardboard, so we recommend using a metal ruler and a craft knife with a sharp blade to cut these pieces out.

\*Chipboard stabilizers - 7" x 10 1/2" Rectangle - Cut 2 of 1/8" Chipboard

### Step 2.

#### MAKING THE POCKETS

A. Pin 2 of the pocket rectangles together with **RIGHT** sides together. Sew around them with a 1/2" seam allowance, leaving a 3" opening on one of the longer sides, so that you can turn the pocket inside **RIGHT**. Trim the seam, clip the corners and turn it **RIGHT** side out, gently pushing the corners out with your turning tool.

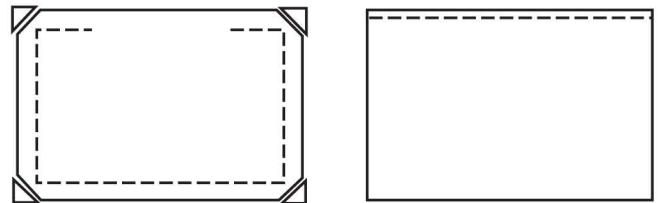

B. Press the pocket, making sure to turn under the opening. Topstitch **1/8"** from the edge, across the open side of the pocket to close. Repeat this step with the other 3 pockets.

C. On each of the Pocket Appliqués, fold 1/2" on each long side to the **WRONG** side of the appliqué. Press the 1/2" down. On each of the short sides, fold and press 1/2" to the **WRONG** side.

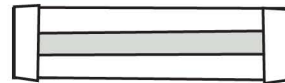

D. Position the appliqué onto a pocket, as shown here, with the **RIGHT** side facing up. Pin into place. Topstitch the appliqué onto the pocket from the edge, along the sides and top of the appliqué, letting the bottom folded edge hang down over the end of the pocket.

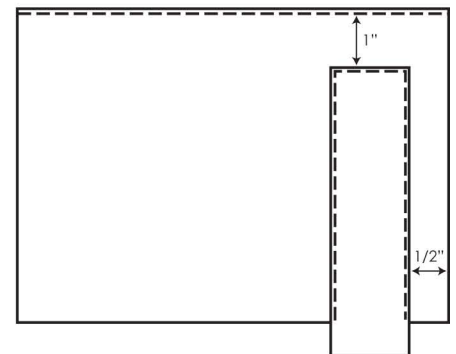

E. On the appliqué piece, measure down 3/4" from the top edge and 1/2" in from one side. Make a small pencil mark. Puncture the appliqué and through the pocket with your awl to make a small hole. Insert a decorative brad through the hole and secure on the back of the pocket.

F. Repeat Step 2D and Step 2E on a second pocket, flipping the position of the appliqué to the opposite side (see layout diagrams on page 4). These two pockets will be your bottom pockets.

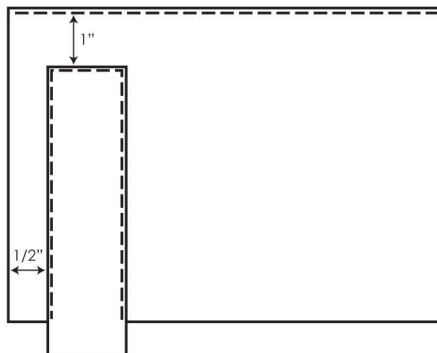

**Step 3.**  
**PLACING YOUR POCKETS**

A. Using the layout diagrams as a guide, (see layout diagrams on page 4) place your two bottom pockets on the two Inner Panels and pin them in place. Make sure that the bottom edge of the pocket appliqué is tucked under the bottom edge of the pocket. Topstitch around the sides and bottom of each pocket 1/8" from the edge, backstitching at the beginning and end.

B. For the top left pocket, fold down the topstitched edge of the pocket 1 1/2" and press with the iron. On the folded-down part, measure and make 2 small pencil marks at the measurements shown here. Puncture the pocket through the folded-down layer only with your awl to make a small hole. Insert a decorative brad through the hole and secure on the back of the folded-down layer.

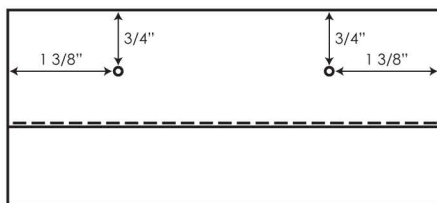

C. For the top right pocket, fold down the topstitched edge of the pocket 1 1/2" and press with the iron. On the folded-down part, measure and make a small pencil mark at the measurements shown here. Puncture the pocket through the folded-down layer only with your awl to make a small hole. Insert a decorative brad through the hole and secure on the back of the folded-down layer.

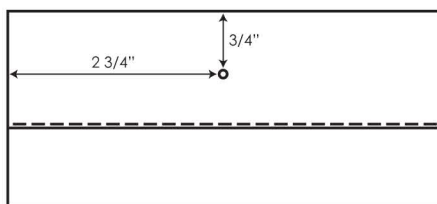

D. Pin the pockets onto the Inner Panels where indicated on the layout diagram (see layout diagrams on page 4). Stitch around the sides and bottom edges 1/8" from the edge, backstitching at the beginning and end. On one of the top pockets, topstitch down the center of the pocket to make it into 2 smaller pockets.

E. On the inside vertical edge of each of the Inner Panels, fold under 1/2" to the **WRONG** side and press. Set the Inner Panels aside for now.

**Step 4.**  
**THE PENCIL POCKET**

A. Fold the Pencil Pocket in half vertically, with **WRONG** sides together. Topstitch 1/4" from the fold.

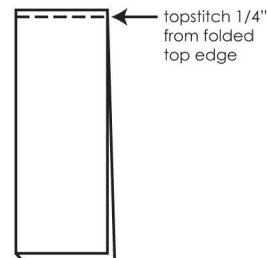

B. Layout one of the Outer Panels with **RIGHT** side facing up. Center the Pencil Pocket along the bottom edge of the Outer Panel and pin in place. The topstitched side of the Pencil Pocket should be the top edge of the pocket.

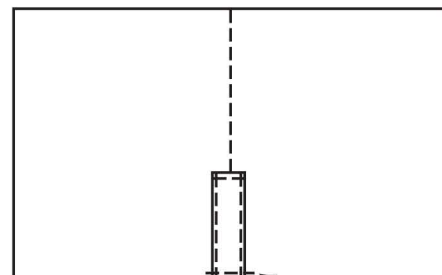

C. Baste the pocket into place along the bottom 3 sides with a 1/4" seam allowance.

baste pencil pocket to outer panel w/ 1/4" seam allowance

**Step 5.**  
**ADD THE COVER STRIPES TO OUTER PANEL**

A. To make the Cover Stripes, lay both pieces out in front of you with **WRONG** sides facing up. Press under 1/2" on each of the long edges.

B. On the remaining Outer Panel, place and pin each Cover Stripe as shown here.

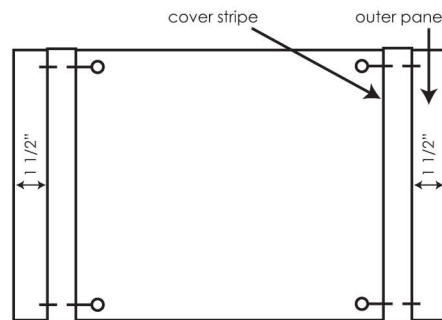

C. Stitch each Cover Stripe to the Outer Panel, topstitching 1/8" from the folded edges of each piece. You may also add decorative stitches down the Cover Stripes, if desired. We added an extra zigzag stitch to our Cover Stripes.

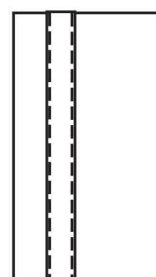

**\*Optional Step**  
**MAKING FABRIC TIES**

A. To make the Fabric Ties, lay both pieces out in front of you with **WRONG** sides facing up. Press under 1/2" on each of the long edges. Press under 1/2" on one short edge of each Fabric Tie. Fold each Fabric Tie in half lengthwise and press.

B. Topstitch along the pressed under short edge and long edge, stitching 1/8" from the edges.

**Step 5.**  
**PUTTING IT ALL TOGETHER**

A. Place each of the Inner Panels on the Outer Panel with the Pencil Pocket, matching them up with the outer edges. Pin in place. The Pencil Pocket's side edges should lie under the Inner Panels.



B. Place each Ribbon (Or Fabric Tie) centered on the short edges of the Outer Panel, over the Inner Panels. Pin in place.

C. Baste around the entire outside edges of the Outer Panels with a  $\frac{3}{8}$ " seam allowance. This will secure everything in place.

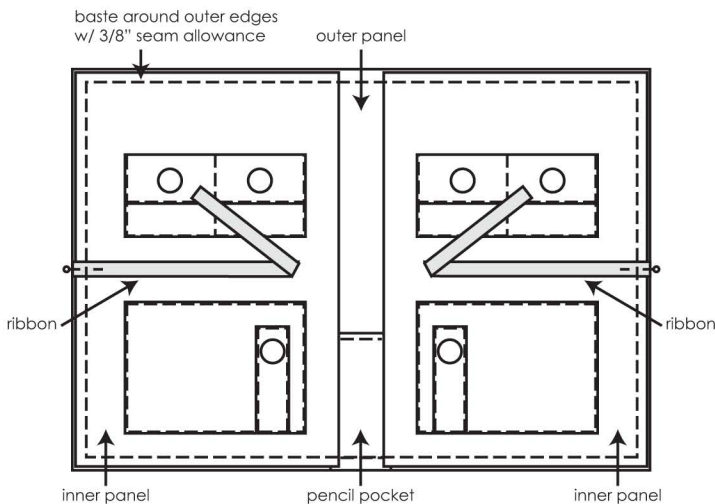

D. Lay the second Outer Panel on top of the first one with **RIGHT** sides together. Pin together.

E. Stitch around the edges with a  $\frac{1}{2}$ " seam allowance, leaving a 4" opening on one side to turn the project **RIGHT** side out. Be careful not to catch the ribbon ends in the seams.

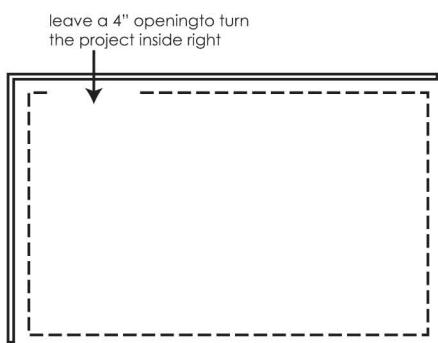

F. Clip the corners and turn the project **RIGHT** side out, gently pushing corners out with the turning tool. Press, tucking in the seam allowance on the opening.

G. Topstitch around the entire Outer Panels,  $\frac{1}{8}$ " from the edge.

**Step 6. INSERTING THE CARDBOARD STABILIZERS**

A. Insert the Cardboard Stabilizers into each Inner Panel. Pin closed the previously pressed-under edges of the Inner Panels.

B. Topstitch  $\frac{1}{8}$ " from the pressed-under edges, through all the layers of fabric (not the cardboard), using your zipper foot. (This step is slightly tricky, so the opening can also be hand sewn closed, if desired.)

Your Large Portfolio is complete!



**Project Two Small Portfolio**

**Materials List:**

- $\frac{3}{8}$  yard of 44" wide lightweight cotton fabric (Fabric A) (We used Olive / Wood Fern hdabs7 from Amy's NIGELLA fabric collection by Rowan)
- $\frac{1}{4}$  yard lightweight cotton canvas
- $\frac{3}{8}$  yard of 44" wide lightweight cotton fabric to coordinate with the first fabric (Fabric B) (We used Celery / Passion Vine hdabs4 from Amy's NIGELLA fabric collection by Rowan)
- 2 10" lengths of  $\frac{1}{2}$ " wide ribbon (We used Amy's Sola Ribbon by K&Company - Product # 556607. You may also make fabric ties. Use the **OPTIONAL** Fabric Tie listed in Step 2.)



**Tools Needed:**

- Ruler
- Sewing Machine
- Scissors
- Turning Tool (Such as a closed pair of scissors)
- Sewing Needle
- Pins
- Pencil

**Finished Size:** 7" x 5  $\frac{1}{2}$ "

**Step 1.**

**CUT THE PIECES OUT OF YOUR FABRIC**

- A. Cut out the pieces as follows:
- Outer Panels - 11" x 7" rectangle
    - Cut 2 of lightweight cotton fabric (Fabric A)
    - Cut 1 of lightweight canvas
  - Inner Pockets - 7" x 5" rectangle - Cut 4 of lightweight cotton fabric

**Step 2.**

**MAKING THE INNER POCKETS**

A. Lay 2 of the Inner Pocket pieces together with **RIGHT** sides facing. Sew across one of the longer edges using a  $\frac{1}{2}$ " seam allowance.

B. Turn the **RIGHT** sides out and press along the sewn edge. Topstitch  $\frac{1}{4}$ " away from the sewn edge. Repeat this step for the second pocket.

**\*Optional Step**

**MAKING FABRIC TIES**

A. To make the Fabric Ties, lay both pieces out in front of you with **WRONG** sides facing up. Press under  $\frac{1}{2}$ " on each of the long edges. Press under  $\frac{1}{2}$ " on one short edge of each Fabric Tie. Fold each Fabric Tie in half lengthwise and press.

B. Topstitch along the pressed under short edge and long edge, stitching  $\frac{1}{8}$ " from the edges.

**Step 3.**

**ATTACHING THE INNER POCKETS AND RIBBONS**

A. Attach the canvas to the **WRONG** side of one of the Outer Panels by basting  $\frac{1}{4}$ " from the edge, all the way around the outside edges.

B. Lay the other Outer Panel in front of you, facing **RIGHT** side up. Lay the pockets on top, matching the outside edges. Pin in place.

C. Center each of the ribbons in the middle of the shorter sides of the outside edges and pin in place.

D. Baste around the edges of the Outer Panel, using a 1/4" seam allowance. This will secure the pocket and ribbons into place.

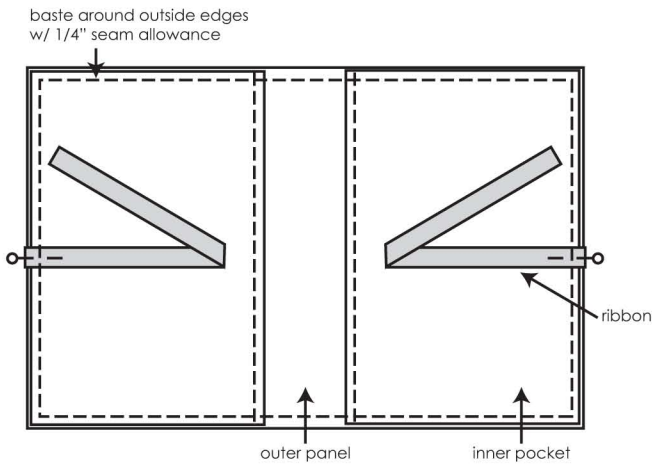

**Step 4.**  
**MAKING THE PORTFOLIO**

A. Lay the second Outer Panel on top of the first panel with **RIGHT** sides facing and pin together.

B. Sew around the edges with a 1/2" seam allowance, leaving a 3" opening on one of the longer sides. Be careful not to catch the ribbon ends in the seams.

C. Clip the corners and turn the project **RIGHT** side out, gently pushing the corners out with the turning tool. Press the sewn edges, turning the seam allowance of the opening under 1/2".

D. Hand sew the opening closed.

Your Small Portfolio is complete!

**LARGE PORTFOLIO LAYOUT DIAGRAM - LEFT SIDE**

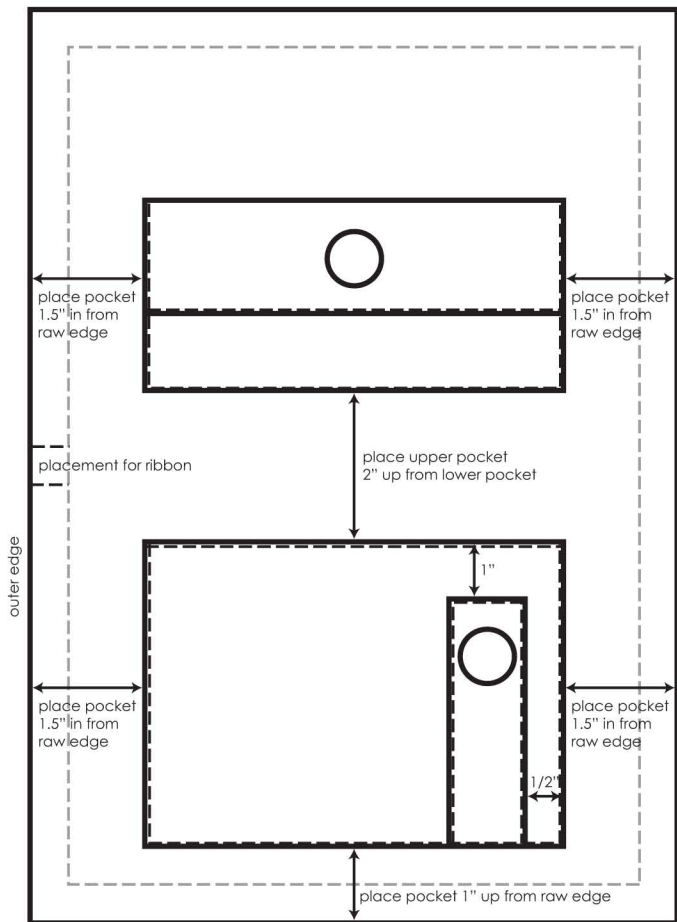

**LARGE PORTFOLIO LAYOUT DIAGRAM - RIGHT SIDE**

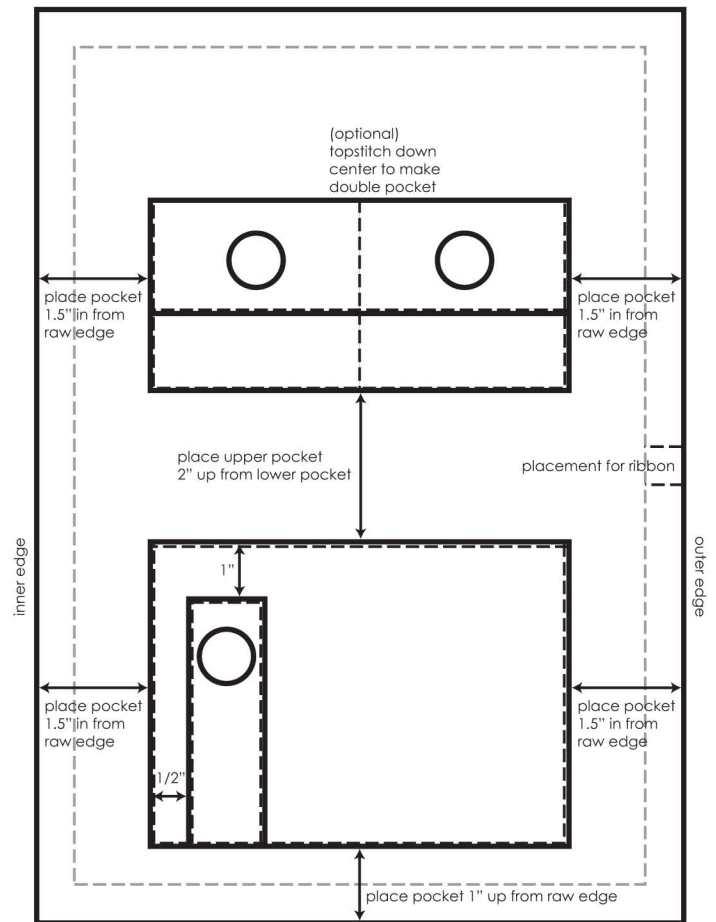

All designs © 2007 Amy Butler Art of the Midwest

All designs, photographs, and images protected by federal copyright. Designs not to be created for commercial sale. All rights reserved. Art of the Midwest, LLC

Printed and produced entirely in the USA